



INSTALLATION MANUAL

REDBARON COMBOHISL™

Anticollision LED light RED / WHITE

DOC.NO: AVE-RBCRW-001-IM

© 2017 Aveo Engineering Group, s.r.o. All rights reserved. The information contained within this document must not be disclosed, copied or reproduced in whole or in part without prior written permission from Aveo Engineering Group, s.r.o. Distribution of this document shall only be as stated in Table 02 unless otherwise agreed by Aveo Engineering Group, s.r.o.

TABLE OF CONTENTS

PART 0	DOCUMENT ADMINISTRATION	3
0.1	DOCUMENT APPROVAL	3
0.2	AMENDMENT RECORD PROCEDURE	4
0.3	EFFECTED PAGES PROCEDURE	4
PART 1	INSTALLATION DATA	5
1.1	REDBARON COMBO HISL™	5
1.2	OPERATING INSTRUCTIONS	5
1.3	INSTALLATION SCHEMATIC / WIRING DIAGRAM	6
1.4	CONTROL & POWER INPUTS	6
1.5	TECHNICAL SPECIFICATION	7
1.6	TECHNICAL DRAWING	8
1.7	WIRING CHART	10
1.8	EQUIPMENT LIMITATION	11
1.9	TESTING THE LIGHTS BEFORE INSTALLATION	11
1.10	NOTES ON INSTALLATION	12
1.11	CARE AND CLEANING OF LIGHTS	12
1.12	CONTINUED AIRWORTHINESS INFORMATION	13

Part 0 Document Administration

0.1 Document Approval

This document has been established in accordance with an alternative procedure to DOA approved under EASA AP429.

This installation manual relates to EASA ETSO Authorization [EASA.210.10053491] and is applicable for the following part number:

RedBaron Combo HISL

AVE-RBCRW-001



Compiled by: _____ 15 August 2017
Petr Jaroš
Engineer, Aveo Engineering Group, s.r.o.



Approved by: _____ 15 August 2017
Georg Hartl
Head of DO, Aveo Engineering Group, s.r.o.

0.2 Amendment Record Procedure

The master copy of this document shall be kept electronically as a read only document under the control of Aveo Engineering Group, s.r.o. as Master Copy.

ALL amendments to this manual will initiate a raise of issue.

The original issue will be identified by "**01**", and subsequent issues will be numbered sequentially from 02 to 99 in Table 01 - **Issue No.** column.

ALL issues of this document will be approved by Head of DO.

Issue No.	Details	Date of issue	Effected pages
01	Initial Issue	28 April 2015	ALL
02	Removing allowed failing LED	29 June 2015	13-16
03	Addition of FAA required statements	10 Novem. 2015	7, 10
04	Section Distribution List removed (not marked) Removed warranty statement (not marked) Added text to wiring diagram Modified technical specification data (typo) Modified technical drawings (not marked)	15 August 2017	5 6 7 8 9,10
05	Added text	01 May 2018	5, 12

Table 01: Record of Document Amendments

0.3 Effected Pages Procedure

ALL pages affected by ANY raise of issue of this manual will be listed in Table 01 - **Effected Pages** Column.

The reason(s) for **EACH** raise of issue and the description of respective change will be provided in Table 01 - **Details** Column.

Changes from the previous issue are shown as follows:

- a) new text is highlighted with yellow shading: **new**
- b) ~~deleted~~ deleted text is shown with yellow shading and a strike through: ~~deleted~~

Part 1 Installation data

1.1 RedBaron Combo HISL™

The incredible and unmatched performance of the RedBaron Combo dual-color LED red and white anti-collision light makes it not only the world's brightest but also the leader in all DO-160 environmental standards compliance.

Main Features:

- Selectable modes of two switches, white or red (RedBaron Combo HISL can be only operated in EITHER RED or WHITE MODE, not simultaneously or it will damage the unit)
- Unmatched strobe intensity in the industry
- Incorporates the world-leading lumen output LED technology
- Low profile and vibration-proof, shock-proof and water-proof design unmatched in the industry

List of the major components (by part number) that make up the equipment complying with the standards prescribed in ETSO:

- **RedBaron Combo HISL** PN: AVE-RBCRW-001

1.2 Operating Instructions

When installed on the aircraft and, using the aircraft's power (28 volts), the light will be at its maximum intensity.
It meets the requirements of ETSO-C96A, classes I, II and III standard for Anti-collision light systems.

1.3 Installation Schematic / Wiring Diagram

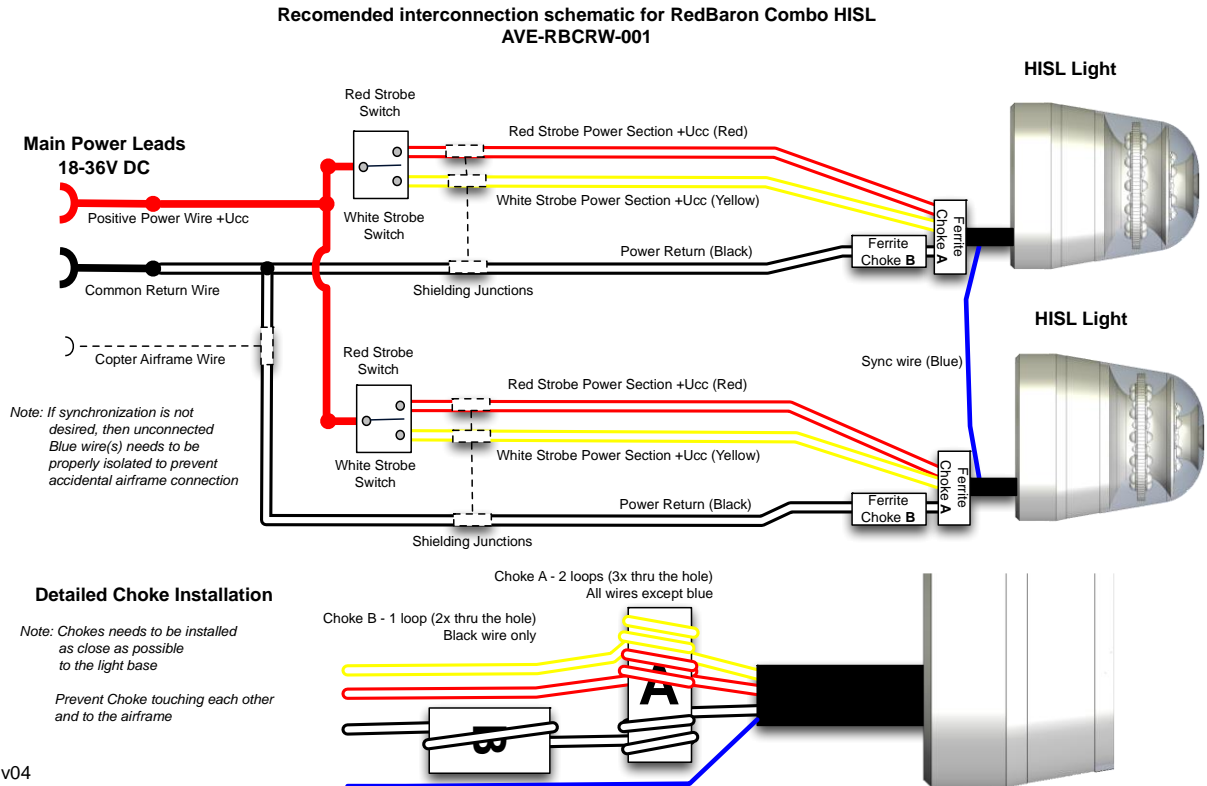

WIRES:

Teflon insulation, 500V, AWG 18, 24

Wire length from base of unit 838 mm [33.00 inches] min.

Red, yellow and black wires are shielded with A ferrite choke -WE74270151

Black wire is shielded also with B ferrite choke - WE74277290.

1.4 Control & Power Inputs

Yellow wire	AWG 18, White strobe
Red wire	AWG 18, Red strobe
Black wire	AWG 18, Ground
Blue wire	AWG 24, Synchro

1.5 Technical Specification

Dimensions:	66 mm x 66 mm x 74.7 mm 2.6" x 2.6" x 2.94"
Weight:	440 g / 0.97 pounds
Operating Voltage Range:	18 – 36 V DC
Operating temperature:	-55 °C ~ + 85 °C -67 °F ~ +185 °F

Power:

- Strobe branch (white), input power:
 - 28 V / 5.0 A : 144 W
- Strobe branch (red), input power:
 - 28 V / 2.5 A : 72 W

LEDs - maximum drive current:

- red LEDs up to 1.0 A
- white LEDs up to 3.0 A

Repetition Flash Rate of Strobe: 48 cycles per minute

Over-voltage protection: YES (+80VDC @ 2second)

Reverse polarity protection: YES (-60VDC)

Recommended size of mounting screw: M5x70mm

Torque requirement for screw M5x70mm: 1.5Nm

Meets and exceeds requirements of:

- ETSO C96a
- SAE AS8017 rev. B and SAE AS8037 rev. A
- DO-160F (G)

1.6 Technical Drawing

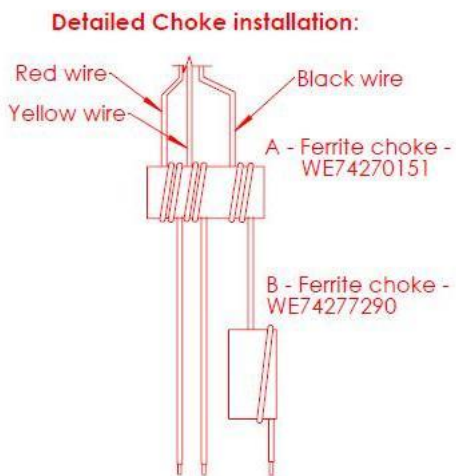
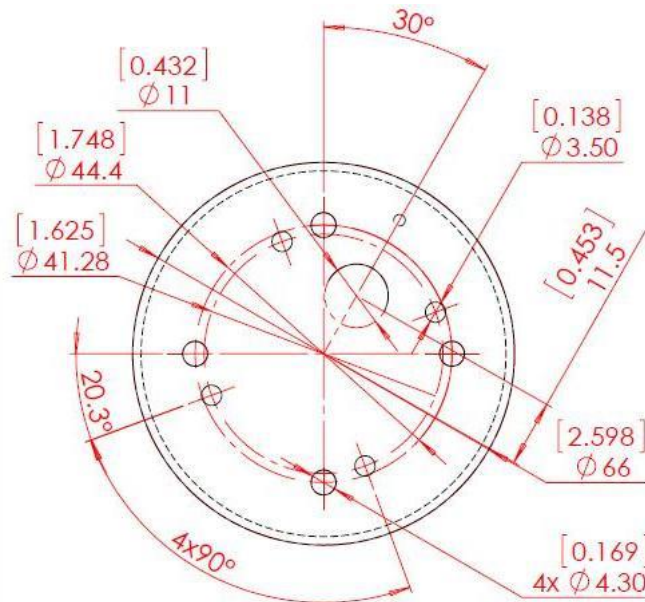

Dimensions in [inches] / millimeters

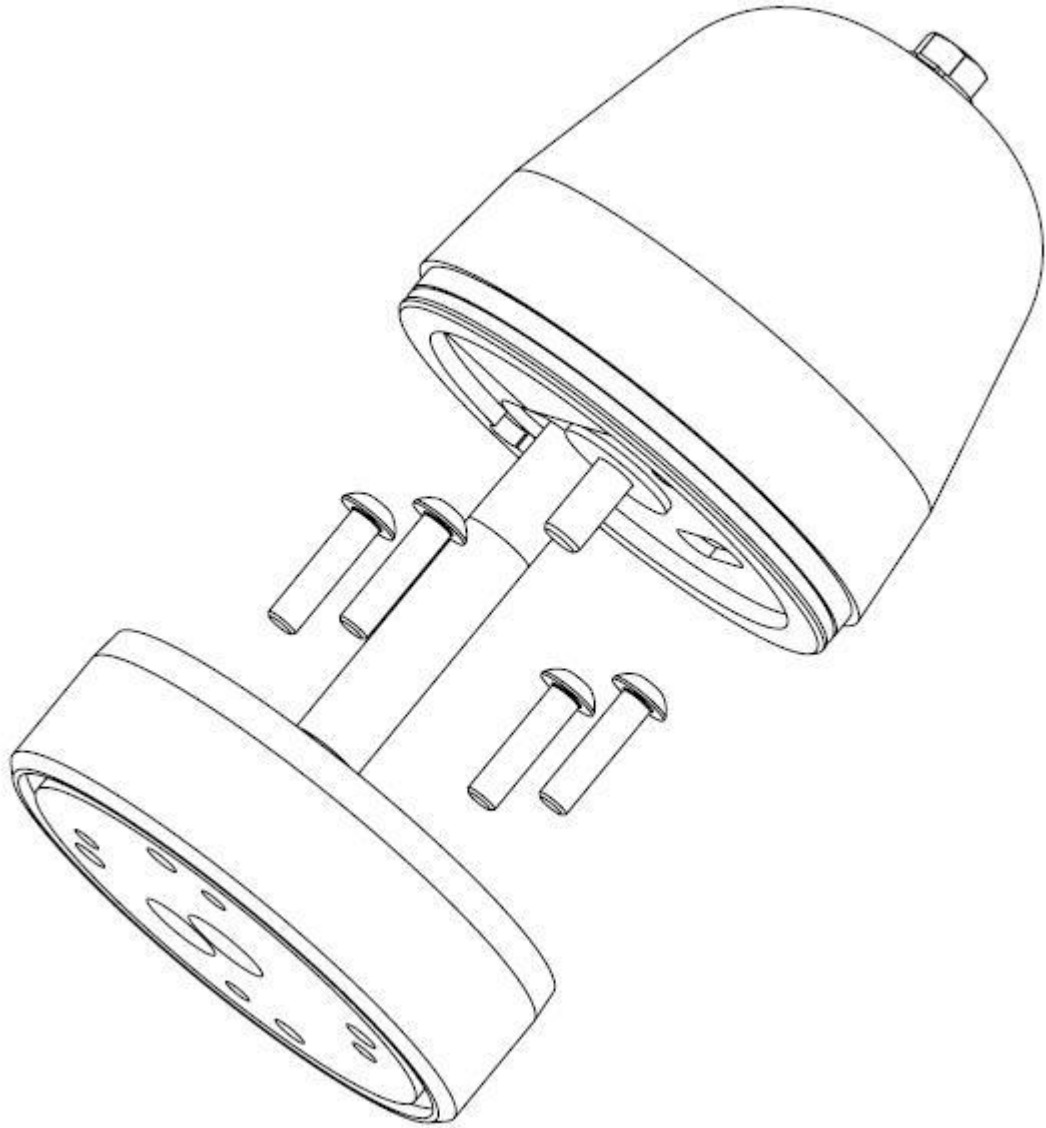

1.7 Wiring Chart

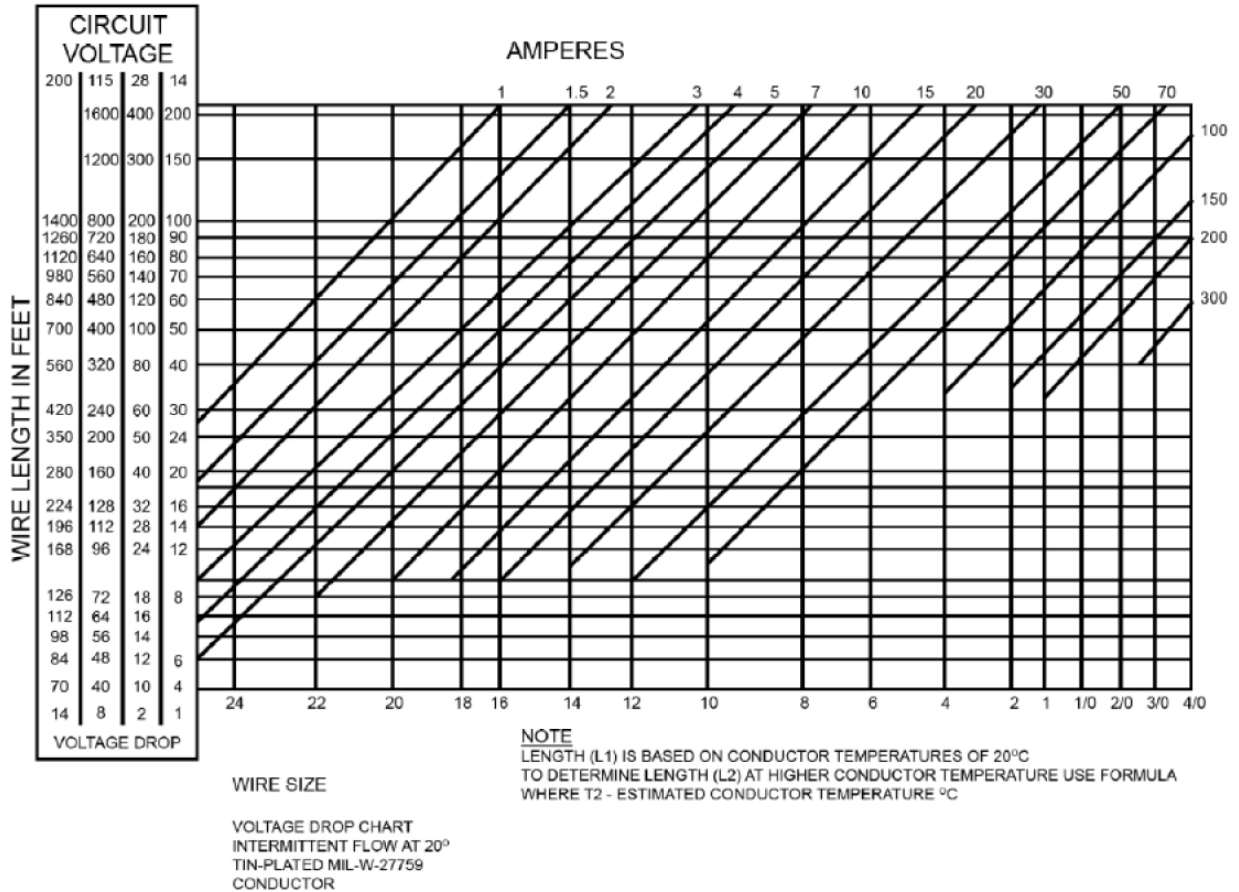

1.8 Equipment Limitation

The **RedBaron Combo HISL™** light should only be powered by 18-36 V DC, typically by a 24 volt aircraft battery.

This article meets the minimum performance and quality control standards required by the technical standard order ETSO C96a. Installation of this article requires separate approval.

Deviations

This article deviates from the ETSO C96a by the usage of newer revisions of the following standards:

- SAE AS 8017 rev. B used instead SAE AS 8017 rev. A

1.9 Testing the Lights before Installation

All Aveo Aviation lights undergo rigorous testing prior to being released from our engineering manufacturing department. This testing involves a burn-in time as well as other function testing. No light is released for sale without undergoing this extensive operational testing.

When you receive the **RedBaron Combo HISL™** light, and wish to test the function of the light prior to installation on your aircraft, please observe the following procedure:

1. Review the written information that is enclosed in the packaging. Warranty information as well as a cautionary note about power supply removal is enclosed in each package.
2. Remove the light from the package. Note that there are four (4) wires coming from each light. The wires are as follows:

Black – Ground (negative lead)
Yellow – White anti-collision light (positive lead)
Red – Red anti-collision light (positive lead)
Blue – Synchro

3. Testing the function of the light can be accomplished using a regular 28V/10A DC power supply (not a battery charger).

Connect the black wire to the ground (negative) leads of a power supply, then connect the yellow wire to the positive (+) leads on the power supply. The anticollision light should start flashing. Connecting the blue wires from each **RedBaron Combo HISL™** light together (and not to the ground or positive terminals on the battery) should result in flashing all lights at once. It indicates the synchronization feature is working properly.

When installed on the aircraft and using the aircraft's power (28 volts), the light will be at its maximum intensity.

If the tests are successfully completed, the light can be installed on the aircraft.

IMPORTANT NOTES:

1. Under no circumstances should any power supply other than a 18-36 V DC, or a 24 volt battery be used to test the lights. Do not use: Battery chargers, battery back-up power devices, or other bench avionics testing methods to test the aviation lights. The lights are functional between 18 and 36 volts. Use of a battery charger or other power unit for testing the lights will void the warranty and may damage the lights.
2. All power supplies for existing strobe lights, flasher beacons, etc. are required to be removed from the aircraft prior to the installation of the Aveo light.
3. RedBaron Combo HISL can be only operated in EITHER RED or WHITE MODE, not simultaneously or it will damage the unit.

If you have any questions about the installation of the lights, please refer to our web site: <http://www.aveoengineering.com>, and check FAQ and other links on our aviation lights web page.

1.10 Notes on Installation

Spread the tightening forces evenly around the mounting hole. Stainless steel screws are recommended to be used for installation. Screw length depends on location of screws on aircraft.

1.11 Care and Cleaning of Lights

Aveo Engineering Aviation Lights are factory polished and delivered as ready to install on the aircraft.

Upon installation, apply one or two coats of quality automotive polish. This should protect the lights from dirt and other environmental factors. Once or twice a month, just refresh the polish and buff the lights by hand.

1.12 Continued Airworthiness Information

From the webpage <http://www.aveoengineering.com/> the customer can download the form F-AVE-001A which shall be used by operator for reporting any occurrences to the Aveo Engineering as the ETSO holder. The form contains the Aveo Engineering telephone number and the occurrence e-mail address (occurrence@aveoengineering.com).

The operator shall report immediately as the ETSO holder is obliged to report occurrences having potential to lead to an unsafe condition within 72 hours.

a. Circuit/Wiring Protection

Each **RedBaron Combo HISL™** light features a **Negative Temperature Coefficient (NTC)** circuit that limits internal temperatures by attenuating operating current (with a corresponding reduction of brightness) when internal temperatures reach a certain threshold. This proprietary circuitry is intended for protecting the light itself, and associated aircraft wiring, from a thermal runaway condition. The operation of strobes without airflow is recommended to be limited in order to avoid heat buildup. This NTC circuitry feature enables the life of LEDs and electronic components to be tripled and thereby provide an even great margin of safety for continued airworthiness due to the dramatic enhancement of electronics reliability.

b. Periodic Inspection Procedure

The **RedBaron Combo HISL™** lights should always be checked for proper operation during preflight. This procedural information is already provided in all general aviation aircraft flight manuals.

The lights should be visually inspected for general condition, proper operation, and correct installation at each inspection to be carried out annually and/or after 100 hours of operation. Any debris or atmospheric deposits accumulated on the surface of the lights should be removed using a UV Wax such as Farecia Profile UV Wax to ensure ongoing optical clarity. In addition, refer to section 1.11 of this installation manual for detailed cleaning instructions.

The following procedure shall be performed:

1. Put on polarized sunglasses or welder goggles to prevent eye damage when looking into the lights.
2. Turn the lights on.
3. Examine the individual LEDs in accordance with the figures 1-6 below. *If any of the LEDs fail, the light shall be removed and sent to Aveo Engineering for replacement under the Warranty Program.*

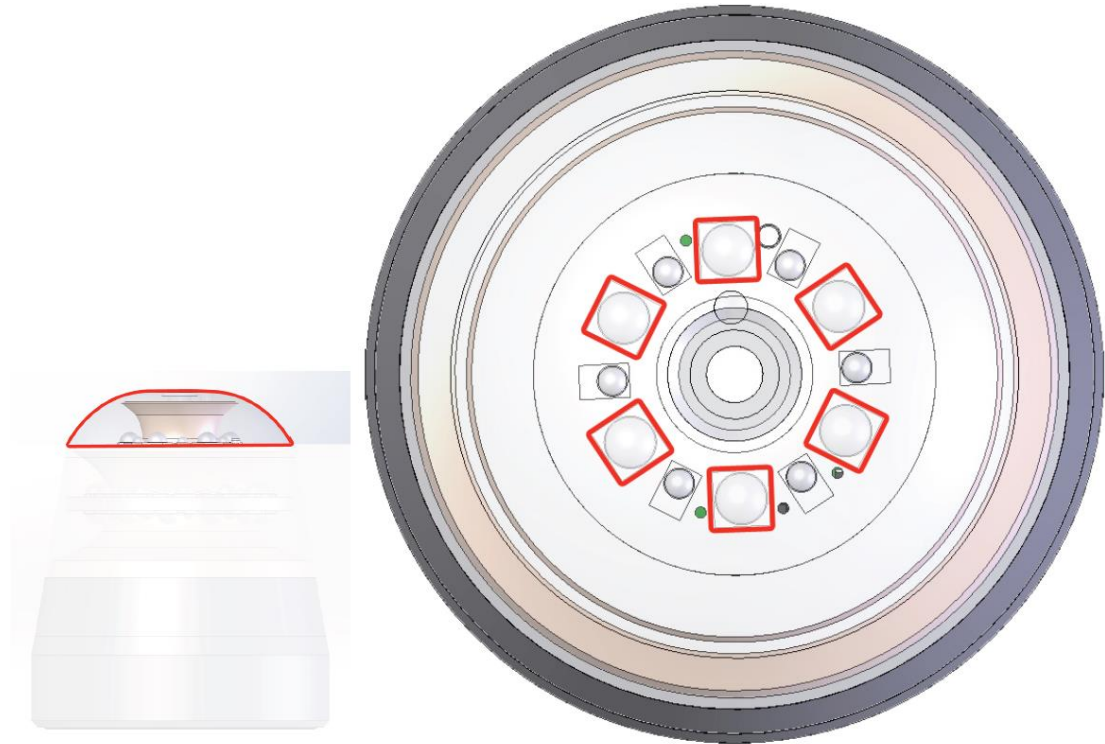

Figure 1: Top White LEDs

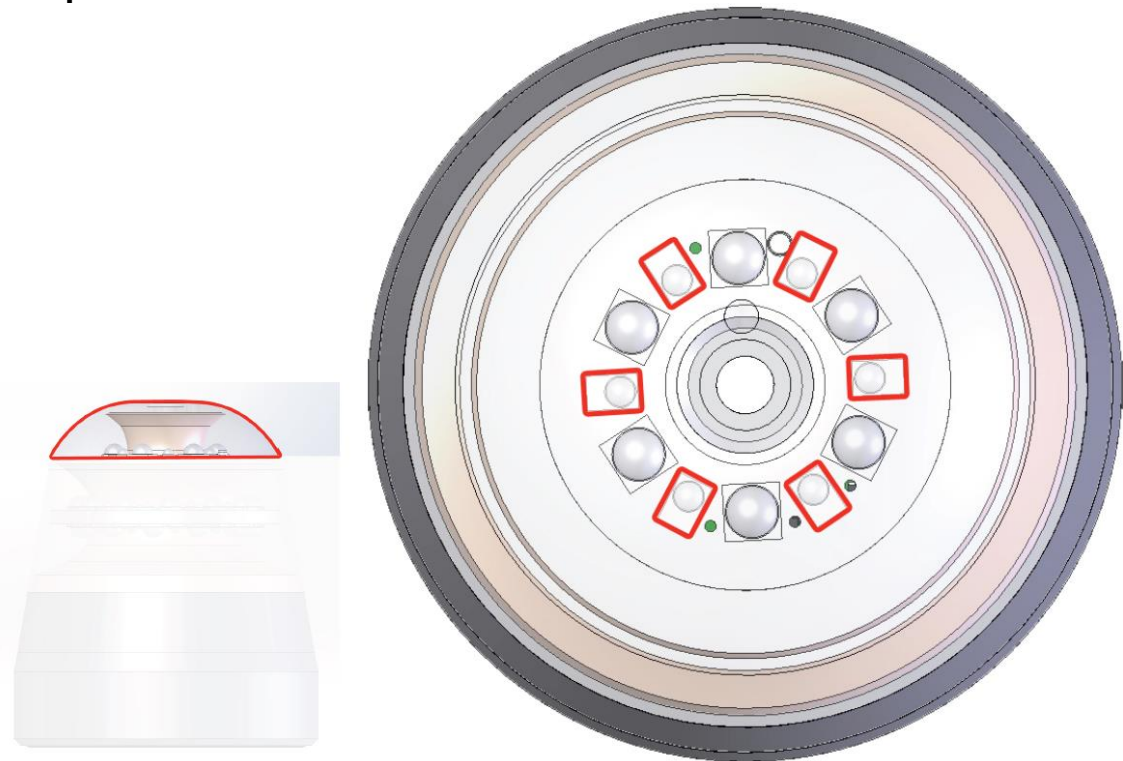

Figure 2: Top Red LEDs



Figure 3: Middle White LEDs



Figure 4: Middle Red LEDs



Figure 5: Bottom White LEDs

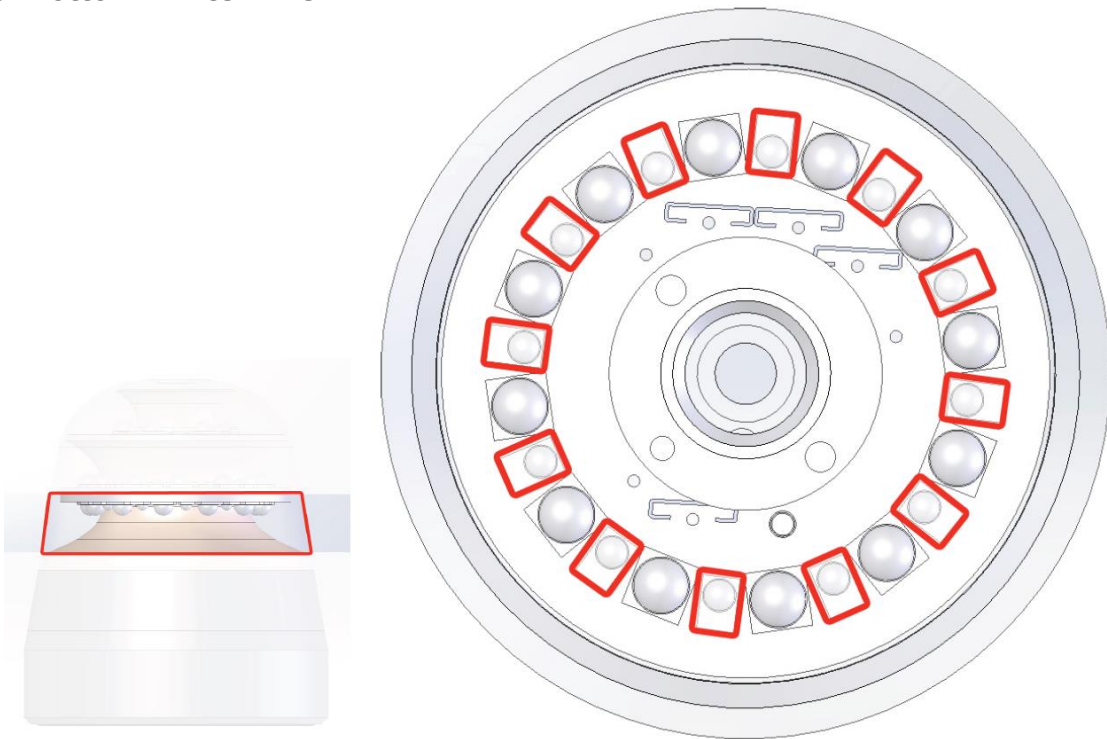

Figure 6: Bottom Red LEDs